



**Wash It.
Dry It.
Store It.®**

Since 1940

The Evolution of Circul-Air Corp and the Dual Purpose Dryer



1940's



1970's



2020's



Circul-Air Corp International est. 1940

Circul-Air Corp (Circul-Air) was founded in 1940 by CT McGraw with his original patents for the electric hose dryer and Roto-Jet hose washer. McGraw was a visionary and saw the need early-on for maintaining the gear firefighters rely on. In the early days, it was all about maintaining the hoses, but in the late 1990s, Circul-Air shifted to turnout gear maintenance and redeveloped its hose dryer to today's Dual Purpose Dryer. In 2015, after 75-years in business, the company started another major transition. Under the new ownership of Justin Christensen, who worked at Circul-Air since 2006, Circul-Air set out to both expand the company's product offerings and to become the sole manufacturer of its products.

In late 2018 Circul-Air opened its first manufacturing facility. Currently Circul-Air operates out of two manufacturing facilities in Ontario, Canada, and a distribution facility just outside Chicago, IL. The expansion into manufacturing allows Circul-Air more options with our dryers and lockers/storage systems. Circul-Air is the only company that currently offers start-to-finish solutions when it comes to NFPA-1851 and properly maintaining the gear that firefighters rely on. Circul-Air products are manufactured in North America for the fire industry specifically.

The Circul-Air difference is our fire industry expertise and turnkey approach to WASH IT. DRY IT. STORE IT. ®. Circul-Air's approach takes the guess-work out of selecting a total equipment solution to comply with the requirements of NFPA-1851's latest revision.

Circul-Air also offers installation and servicing solutions. Circul-Air has a dedicated North American-wide team of technicians and consultants to help find solutions designed to fit within your station, your budget and your requirements.

Whether it is extractors, dryers or storage solutions, Circul-Air is here to help so that you can Fight Fires, Not Cancer. Contact us today to get started:

call: 800-795-1150 option 2
 email: sales@circul-air-corp.com
 or visit: Circul-Air-Corp.com

Table of Contents

Wash It.

Extractors	6
RotoJet Hose Washer	20
Roto-Decon Extractor	21
Extractor Bases	22
Extractor Pumps and Chemicals	23

Dry It.

Drying Cabinets	26
Portable Dryers	30
Tumble Dryers	32

Store It.

Storage Lockers	40
Dual Purpose Drying Rack	46
Hose Storage Racks	47
Mobile Work or Storage Cabinets	49

Accessories, Services, Warranty & Support

Accessories	52
Service and Warranty Commitment	54
Installation Services	54
Design Services	55
Support Teams	55

Wash It.



**Widest Extractor Selection
Best-in-Class Program Options**

Features “Circul-Air Fire Package” Programming:

**Programmed to NFPA-1851 compliant wash cycles, proven and
verified with multiple ISPs**

**Chemical dosing pumps pre-configured to extractor and ISP-
verified detergent**

1 Gallon of [CitroSqueeze®](#)

Simple Button Start for all Programs

**Dedicated Fire PPE Wash Cycles as per NFPA-1851
2020 edition: Outer Shell/Wildland Gear; Inner Liner/
Moisture Barrier & Thermal Batting; Bloodborne/
Blood & Biological Contamination; Extra Spin;
Towels/General Wash**

EXPRESS BASIC – 22 LB. – COMMERCIAL GRADE SOFT MOUNT EXTRACTOR (CACSM-22-Basic)



Mount Method	Soft Mount
Unit Capacity (lbs/pieces)	22/4
Dimensions (wxdxh in inches)	27x29.8x38.7
Unit Weight (lbs)	191.8
Unit Door Opening (in)	15.5
Unit Floor to Door (in)	14
Electrical Configuration	120v/60/1
Electrical Circuit Breaker	10
Water Supply Inlets	2@3/4
Water Supply Flow (gpm)	8
Water Supply (psi)	15-60
Water Drain (method/size)	Pumped Wall/1"
Unit Drum Volume (ft ³)	3.6

The CACSM-22-Basic "Express Series" is an entry-level NFPA 1851:2020 compliant extractor offered for situations where budget takes precedence over efficiency. This extractor will wash 2 sets of liners and hoods or 2 sets of outer shells (4 pieces of gear.) Includes pre-configured wash cycles to conform to NFPA 1851:2020 recommended wash cycles for outer shells, thermal liners/moisture barriers and disinfection.

- Dedicated Fire PPE Wash Cycles as per NFPA-1851 2020 edition
- Features the "Circul-Air Fire Package" minus the complimentary dosing pump
- Cleans 4 pieces of gear
- Commercial grade construction and stainless steel drum for heavy-duty washing
- Optimal for smaller stations with limited infrastructure and budget
- Easy and ready-to-use installation
- 2-year warranty

EXPRESS PRO – 22 LB. – COMMERCIAL GRADE SOFT MOUNT EXTRACTOR (CACSM-22-PRO)

Mount Method	Soft Mount
Unit Capacity (lbs/pieces)	22/4
Dimensions (wxdxh in inches)	27x29.8x38.7
Unit Weight (lbs)	191.8
Unit Door Opening (in)	15.5
Unit Floor to Door (in)	14
Electrical Configuration	120v/60/1
Electrical Circuit Breaker	10
Water Supply Inlets	2@3/4
Water Supply Flow (gpm)	8
Water Supply (psi)	15-60
Water Drain (method/size)	Pumped Wall/1"
Unit Drum Volume (ft ³)	3.6



The CACSM-22-Pro "Express Series" system includes everything to get up and cleaning gear on the same day. Includes pre-wired dosing pump that has been pre-programmed to interact with the extractor to deliver the appropriate level of [CitroSqueeze®](#) detergent. This extractor will wash 2 sets of liners and hoods or 2 sets of outer shells (4 pieces of gear). Extractors are pre-programmed to wash cycles to conform to NFPA 1851:2020 recommended wash cycles for outer shells, thermal liners/moisture barriers and disinfection.

- Dedicated Fire PPE Wash Cycles as per NFPA-1851 2020 edition
- Features the "Circul-Air Fire Package"
- Cleans 4 pieces of gear
- Commercial grade construction and stainless steel drum for heavy-duty washing
- Optimal for smaller stations with limited infrastructure
- Easy and ready-to-use installation
- 2-year warranty



EXPRESS PRO – 35 LB. – COMMERCIAL GRADE SOFT MOUNT EXTRACTOR (CACSM-35-PRO)



Mount Method	Soft Mount
Unit Capacity (lbs/pieces)	35/7
Dimensions (wxdxh in inches)	29x32x40.8
Unit Weight (lbs)	222
Unit Door Opening (in)	16.5
Unit Floor to Door (in)	15
Electrical Configuration	120v/60/1
Electrical Circuit Breaker	15
Water Supply Inlets	2@3/4
Water Supply Flow (gpm)	8
Water Supply (psi)	15-60
Water Drain (method/size)	Pumped Wall/1"
Unit Drum Volume (ft ³)	5.2

The CACSM-35-Pro "Express Series" has everything that the 22 capacity pro series has with the added capability to run extended rinse / spin cycles to remove more toxins from your gear and lessen the dry-time. This extractor will wash 3 sets of liners and hoods or 3 sets of outer shells (7 pieces of gear). Includes pre-configured wash cycles to conform to NFPA 1851:2020 recommended wash cycles for outer shells, thermal liners/moisture barriers and disinfection.

- Dedicated Fire PPE Wash Cycles as per NFPA-1851 2020 edition
- Features the "Circul-Air Fire Package"
- Cleans 7 pieces of gear
- Commercial grade construction and stainless steel drum for heavy-duty washing
- Optimal for standard stations
- Easy and ready-to-use installation
- 2-year warranty

CIRCUL-AIR HD INDUSTRIAL GRADE 20 LB, SOFT MOUNT EXTRACTOR (CACSHD-20 or CACSHD-20-G)



Mount Method	Soft Mount
Unit Capacity (lbs/pieces)	20/4
Dimensions (wxdxh in inches)	27x27.6x42.5
Unit Weight (lbs)	249
Unit Door Opening (in)	12.7
Unit Floor to Door (in)	15.4
Electrical Configuration	120/60/1, 3-prong cord, 15
Electrical Circuit Breaker	15
Water Supply Inlets	2 @ 3/4
Water Supply Flow (gpm)	8
Water Supply (psi)	30-60
Water Drain (method/size)	Pump 1" Gravity 2"
Unit Drum Volume (ft ³)	2.8

This 20-lb capacity HD series soft mount extractor is the smallest machine to offer the expanded programming ability to deliver an ISP-level clean. Its lighter capacity cleans 2 sets of thermal liner/moisture barriers or 2 sets of outer shells (4 pieces of gear). It connects to 120v power. Depending on your station's outfitting, choose between the model that has the option for pumped wall drain or the model that offers gravity floor drain.

- Dedicated Fire PPE Wash Cycles as per NFPA-1851 2020 edition
- Features the "Circul-Air Fire Package"
- Cleans 4 pieces of gear
- Industrial grade construction and stainless steel drum for heavy-duty washing
- Optimal for smaller stations with limited infrastructure
- Easy and ready-to-use installation
- 2-year warranty



CIRCUL-AIR HD INDUSTRIAL GRADE 30 LB, SOFT MOUNT EXTRACTOR (CACSHD-30)



Mount Method	Soft Mount
Unit Capacity (lbs/pieces)	30/6
Dimensions (wxdxh in inches)	31.3x34.9x52.2
Unit Weight (lbs)	758
Unit Door Opening (in)	12.9
Unit Floor to Door (in)	20
Electrical Configuration	208-240/60/1, 2W+G, 10
Electrical Circuit Breaker	15
Water Supply Inlets	2 @ 3/4
Water Supply Flow (gpm)	16
Water Supply (psi)	30-60
Water Drain (method/size)	Gravity/3"
Unit Drum Volume (ft ³)	4.4

This 30-lb capacity HD series soft mount washes 3 sets of thermal liner/moisture barriers or 3 sets of outer shells (6 pieces of gear). This is the smallest machine to require higher voltage (208-240 single phase). The expanded pre-programmed wash cycles allow for an ISP-level of cleaning.

- Dedicated Fire PPE Wash Cycles as per NFPA-1851 2020 edition
- Features the "Circul-Air Fire Package"
- Cleans 6 pieces of gear
- Industrial grade construction and stainless steel drum for heavy-duty washing
- Optimal for standard stations
- Easy and ready-to-use installation
- 2-year warranty

CIRCUL-AIR HD INDUSTRIAL GRADE 35 LB, HARD MOUNT EXTRACTOR (CACMHD-35)

Mount Method	Hard Mount
Unit Capacity (lbs/pieces)	33/7
Dimensions (wxdxh in inches)	29.5x32.25x52.9
Unit Weight (lbs)	525
Unit Door Opening (in)	12.9
Unit Floor to Door (in)	20
Electrical Configuration	208-240/60/1/ 2w+G
Electrical Circuit Breaker	10
Water Supply Inlets	2 @ 3/4
Water Supply Flow (gpm)	16
Water Supply (psi)	30-60
Water Drain (method/size)	Gravity/3"
Unit Drum Volume (ft ³)	4.5



This 35-lb capacity HD series hard mount is a great station-level extractor. It washes 3 sets of thermal liner/moisture barriers or 3.5 sets of outer shells (7 pieces of gear). The expanded pre-programmed wash cycles allow for an ISP-level of cleaning.

- Dedicated Fire PPE Wash Cycles as per NFPA-1851 2020 edition
- Features the "Circul-Air Fire Package"
- Cleans 7 pieces of gear
- Industrial grade construction and stainless steel drum for heavy-duty washing
- Optimal for standard stations with reinforced flooring available
- Easy and ready-to-use installation
- 2-year warranty



CIRCUL-AIR HD INDUSTRIAL GRADE 40 LB, SOFT MOUNT EXTRACTOR (CACSHD-40)



Mount Method	Soft Mount
Unit Capacity (lbs/pieces)	40/8
Dimensions (wxdxh in inches)	34.2x37.9x55.3
Unit Weight (lbs)	1049
Unit Door Opening (in)	16.8
Unit Floor to Door (in)	20.3
Electrical Configuration	208-240/60/1, 2W+G, 10
Electrical Circuit Breaker	15
Water Supply Inlets	2 @ 3/4
Water Supply Flow (gpm)	16
Water Supply (psi)	30-60
Water Drain (method/size)	Gravity/3"
Unit Drum Volume (ft ³)	6.1

This 40-lb capacity HD series soft mount is a great size for a single-engine station extractor. It washes 4 sets of thermal liner/moisture barriers or 4 sets of outer shells. (8 pieces of gear). The expanded pre-programmed wash cycles allow for an ISP-level of cleaning.

- Dedicated Fire PPE Wash Cycles as per NFPA-1851 2020 edition
- Features the "Circul-Air Fire Package"
- Cleans 8 pieces of gear
- Industrial grade construction and stainless steel drum for heavy-duty washing
- Optimal for standard stations
- Easy and ready-to-use installation
- 2-year warranty

CIRCUL-AIR HD INDUSTRIAL GRADE 40 LB, HARD MOUNT EXTRACTOR (CACHMHD-40)

Mount Method	Hard Mount
Unit Capacity (lbs/pieces)	40/8
Dimensions (wxdxh in inches)	29.5x41.8x52.9
Unit Weight (lbs)	562
Unit Door Opening (in)	12.9
Unit Floor to Door (in)	20
Electrical Configuration	208-240/60/1/2w+G
Electrical Circuit Breaker	10
Water Supply Inlets	2 @ 3/4
Water Supply Flow (gpm)	16
Water Supply (psi)	30-60
Water Drain (method/size)	Gravity/3"
Unit Drum Volume (ft ³)	6



This 40-lb capacity HD series hard mount is a great station-level extractor. It washes 4 sets of thermal liner/moisture barriers or 4 sets of outer shells (8 pieces of gear). The expanded pre-programmed wash cycles allow for an ISP-level of cleaning.

- Dedicated Fire PPE Wash Cycles as per NFPA-1851 2020 edition
- Features the "Circul-Air Fire Package"
- Cleans 8 pieces of gear
- Industrial grade construction and stainless steel drum for heavy-duty washing
- Optimal for standard stations with reinforced flooring available
- Easy and ready-to-use installation
- 2-year warranty



CIRCUL-AIR HD INDUSTRIAL GRADE 55 LB, HARD MOUNT EXTRACTOR (CACHMHD-55)



Mount Method	Hard Mount
Unit Capacity (lbs/pieces)	55/11
Dimensions (wxdxh in inches)	34.3x44.8x56.1
Unit Weight (lbs)	741
Unit Door Opening (in)	16.8
Unit Floor to Door (in)	19.7
Electrical Configuration	208-240/60/1/2w+G
Electrical Circuit Breaker	10
Water Supply Inlets	2 @ 3/4
Water Supply Flow (gpm)	16
Water Supply (psi)	30-60
Water Drain (method/size)	Gravity/3"
Unit Drum Volume (ft ³)	8

This 55-lb capacity HD series hard mount extractor is a great multi-engine station-level extractor. It washes 5 sets of thermal liner/moisture barriers and hoods or 5.5 sets of outer shells (11 pieces of gear). The expanded pre-programmed wash cycles allow for an ISP-level of cleaning.

- Dedicated Fire PPE Wash Cycles as per NFPA-1851 2020 edition
- Features the "Circul-Air Fire Package"
- Cleans 11 pieces of gear
- Industrial grade construction and stainless steel drum for heavy-duty washing
- Optimal for larger stations with reinforced flooring available
- Easy and ready-to-use installation
- 2-year warranty

CIRCUL-AIR HD INDUSTRIAL GRADE 60 LB, SOFT MOUNT EXTRACTOR (CACSHD-60)

Mount Method	Soft Mount
Unit Capacity (lbs/pieces)	60/12
Dimensions (wxdxh in inches)	38.4x48.2x58.1
Unit Weight (lbs)	1289
Unit Door Opening (in)	16.8
Unit Floor to Door (in)	22.9
Electrical Configuration	208-240V/60/1/2+G (3 phase option available)
Electrical Circuit Breaker	15
Water Supply Inlets	2 @ 3/4
Water Supply Flow (gpm)	16
Water Supply (psi)	30-60
Water Drain (method/size)	Gravity/3"
Unit Drum Volume (ft ³)	8.4



This 60-lb HD series soft mount is a great multi-engine station-level extractor. It washes 6 sets of thermal liner/moisture barriers or 6 sets of outer shells (12 pieces of gear). The expanded pre-programmed wash cycles allow for an ISP-level of cleaning.

- Dedicated Fire PPE Wash Cycles as per NFPA-1851 2020 edition
- Features the "Circul-Air Fire Package"
- Cleans 12 pieces of gear
- Industrial grade construction and stainless steel drum for heavy-duty washing
- Optimal for larger stations with increased gear needs
- Easy and ready-to-use installation
- 2-year warranty



CIRCUL-AIR HD INDUSTRIAL GRADE 70 LB, HARD MOUNT EXTRACTOR (CACHMHD-70 or CACHMHD-70-3)



Mount Method	Hard Mount
Unit Capacity (lbs/pieces)	70/14
Dimensions (wxdxh in inches)	34.3x45x57.7
Unit Weight (lbs)	899
Unit Door Opening (in)	16.7
Unit Floor to Door (in)	21.4
Electrical Configuration	208-240/60/1/2w+G 208-240/60/3/3w+G
Electrical Circuit Breaker	15
Water Supply Inlets	2 @ 3/4
Water Supply Flow (gpm)	16
Water Supply (psi)	30-60
Water Drain (method/size)	Gravity/3"
Unit Drum Volume (ft ³)	9.7

This 70-lb capacity HD series hard mount extractor is great for centralized cleaning of gear from multiple stations or multi-engine stations. It washes 7 sets of thermal liner/moisture barriers or 7 sets of outer shells (14 pieces of gear). The expanded pre-programmed wash cycles allow for an ISP-level of cleaning.

- Dedicated Fire PPE Wash Cycles as per NFPA-1851 2020 edition
- Features the "Circul-Air Fire Package"
- Cleans 14 pieces of gear
- Industrial grade construction and stainless steel drum for heavy-duty washing
- Optimal for large stations with reinforced flooring available
- Easy and ready-to-use installation
- 2-year warranty

CIRCUL-AIR HD INDUSTRIAL GRADE 70 LB, SOFT MOUNT EXTRACTOR (CACSHD-70 or CACSHD-70-3)

Mount Method	Soft Mount
Unit Capacity (lbs/pieces)	70/14
Dimensions (wxdxh in inches)	41.5x52x59.1
Unit Weight (lbs)	1401
Unit Door Opening (in)	16.8
Unit Floor to Door (in)	23.6
Electrical Configuration	208-240V/60/1/2+G (3phase option available)
Electrical Circuit Breaker	15
Water Supply Inlets	2 @ 3/4
Water Supply Flow (gpm)	16
Water Supply (psi)	30-60
Water Drain (method/size)	Gravity/3"
Unit Drum Volume (ft ³)	9.9



This 70-lb HD series soft mount extractor is great for centralized cleaning of gear from multiple stations or multi-engine stations. It washes 7 sets of thermal liner/moisture barriers or 7 sets of outer shells (14 pieces of gear). The expanded pre-programmed wash cycles allow for an ISP-level of cleaning.

- Dedicated Fire PPE Wash Cycles as per NFPA-1851 2020 edition
- Features the "Circul-Air Fire Package"
- Cleans 14 pieces of gear
- Industrial grade construction and stainless steel drum for heavy-duty washing
- Optimal for large stations
- Easy and ready-to-use installation
- 2-year warranty



CIRCUL-AIR HD INDUSTRIAL GRADE 80 LB SOFT MOUNT EXTRACTOR (CACSHD-80)



Mount Method	Soft Mount
Unit Capacity (lbs/pieces)	80/16
Dimensions (wxdxh in inches)	41.5x52x59.1
Unit Weight (lbs)	1499
Unit Door Opening (in)	16.8
Unit Floor to Door (in)	23.6
Electrical Configuration	208-240/60/3, 3W+G, 10
Electrical Circuit Breaker	15
Water Supply Inlets	2 @ 3/4
Water Supply Flow (gpm)	16
Water Supply (psi)	30-60
Water Drain (method/size)	Gravity/3"
Unit Drum Volume (ft ³)	11.3

This 80-lb capacity HD series soft mount extractor is great for centralized cleaning of gear from multiple stations or multi-engine stations. It washes 8 sets of thermal liner/ moisture barriers or 8 sets of outer shells (16 pieces of gear). The expanded pre-programmed wash cycles allow for an ISP-level of cleaning.

- Dedicated Fire PPE Wash Cycles as per NFPA-1851 2020 edition
- Features the "Circul-Air Fire Package"
- Cleans 16 pieces of gear
- Industrial grade construction and stainless steel drum for heavy-duty washing
- Optimal for large stations
- Easy and ready-to-use installation
- 2-year warranty

CIRCUL-AIR HD INDUSTRIAL GRADE 90 LB SOFT MOUNT EXTRACTOR (CACSHD-90)

Mount Method	Soft Mount
Unit Capacity (lbs/pieces)	90/18
Dimensions (wxdxh in inches)	54.7x57.3x70.8
Unit Weight (lbs)	3106
Unit Door Opening (in)	22
Unit Floor to Door (in)	25.9
Electrical Configuration	208-240/60/3, 3W+G, 15
Electrical Circuit Breaker	15
Water Supply Inlets	2 @ 1"
Water Supply Flow (gpm)	26
Water Supply (psi)	30-60
Water Drain (method/size)	Gravity/3"
Unit Drum Volume (ft ³)	13.9



This 90-lb capacity HD series soft mount extractor is great for centralized cleaning of gear from multiple stations or multi-engine stations. It washes 9 sets of thermal liner/ moisture barriers or 9 sets of outer shells (18 pieces of gear). The expanded pre-programmed wash cycles allow for an ISP-level of cleaning.

- Dedicated Fire PPE Wash Cycles as per NFPA-1851 2020 edition - Annex
- Features the "Circul-Air Fire Package"
- Cleans 18 pieces of gear
- Industrial grade construction and stainless steel drum for heavy-duty washing
- Optimal for large stations
- Easy and ready-to-use installation
- 2-year warranty



ROTOJET HOSE WASHER



Dimensions (wxdxh in inches)	81x25x51
Electrical Configuration	120V, 60Hz, 20A
Description	Wash up to 30 fpm of hose 1-1/4 to 5" diameter
Water Specifications	60-Gal pre-soak chamber w/ adjustable guides 3/4" Inlet for water (45-90 psi) 1-1/4" outlet for discharge water

The Circul-Air RotoJet Hose Washer completely eliminates the backbreaking and resource-depleting chore of manually scrubbing-down hose. Effectively removing mud, gravel, glass, and other potential toxins and carcinogens from your hose, the RotoJet enables maximum hose-life and thorough deep-cleaning. Clean and properly maintained equipment allows you to get down to the job at hand: saving lives!

- 4 industrial nylon brushes and 4 adjustable spray jets for quick and thorough scrubbing
- Foot pedal operation for one- or two-person use
- Industrial powder coat finish enhancing durability
- Proudly made in North America
- 1-year warranty

ROTO-DECON EXTRACTOR

Dimensions (wxdxh in inches)	Closed: 36x46x80 Door Open 90°: 52x51x80 Door Open 180°: 78x44x80
Unit Weight (lbs)	800 (empty) 950 (w 35 gal. of water)
Cleaning Chamber Volume (ft ³)	14
Electrical Configuration	208/1/60 or 240/1/60 with 8" cord with Nema connector
Cold & Hot (120-145°F) Water Specifications	3/4" connection, 3-8 gpm, 40-85 psi
Water Discharge	Gravity drain; max discharge 30 gpm
Max Upper & Lower Tank Temperature per NFPA 1851 (F)	105
Tank Volume (upper tank/lower tank in gallons)	4/30



The Roto-Decon extractor is the latest addition to the Circul-Air Family. A purpose build cabinet extractor for the decontamination of self-contained breathing apparatus, PPE and other firefighting accessories to NFPA 1851 standards, the Roto-Decon doubles as a wet station for equipment pre-cleaning or gross decon. The Roto-Decon uses the right amount of water, detergent and time to get the job done right. Working with industry experts we have developed different methods of cleaning, encouraging more separation of gear and the proper use of manufacturer accessories.

- Cleans SCBA harness and mask, SCBA bottles or hardgoods, helmets, gloves or boots (includes chemicals and accessory racking to get you started)
- Extended fresh water rinse, clean water only, extra filtration and boiler heat only features selectable
- Intuitive and flexible 7.0" touchscreen is upgradable as codes update
- Rotary table with jog function and split doors for ergonomic loading
- Proudly made in North America
- 3-year warranty



EXTRACTOR BASES



Extractors have an optional base available for purchase. Bases allow for easier extractor-installation and raise extractors off of the floor, increasing accessibility.

- Heavy-duty design; manufacturer specific
- Welded steel construction
- Pre-drilled locating and mounting holes
- Standard 6" elevation

Available for:

- CAC-SM22 and SM35 PRO
- CAC-SHD 20 - 70
- CAC-HMHD 30 - 70

Part Number: CACHMBS-XX

Soft Mount bases available upon request

Install Hardware & Chemical Kits Available

EXTRACTOR PUMPS AND CHEMICALS



The Circul-Air Fire Package comes with a complimentary SEKO-2 Pump and a gallon of [CitroSqueeze®](#) to get you started. That way, all you have to do is plug your extractor in and wash your turnout gear. Pumps and [CitroSqueeze®](#) are also able to be purchased independently.

Pumps Included in Fire Package:

- Pre-wired dosing signaled from extractor or manual switch
- Pre-programmed to dispense appropriate amount of detergent
- Basic install and low maintenance pumps
- Precise detergent discharge resulting in consistent gear cleaning

Pumps purchased independently do not include pre-programming.

Circul-Air recommends the use of [CitroSqueeze®](#).

[CitroSqueeze®](#) Turnout Gear & PPE Cleaner is the leading technical detergent available in North America for the safe cleaning of oil, soot, grease and other hydrocarbon contaminants from all types of PPE apparel and FR clothing. Simple to use, biodegradable, and uniquely effective, [CitroSqueeze®](#) has been the leader and #1 choice for cleaning fire fighters' PPE for over 20 years.

It is the ONLY NFPA 1851 compliant PPE turnout gear cleaner that has been tested extensively by the industry's textile suppliers. It is PROVEN to maintain the protective quality of PPE and turnout apparel.

Available online or through your local distributor. Included in the Circul-Air Fire Package.



Dry It.



Wide Selection for All Applications and Needs

Industry-Leading Warranties

NFPA-1851:2020 Compliant

**Cabinets and Portable Dryers Proudly Made in North
America**

V511 EXPRESS 2 GEAR DRYING CABINET / 120V



Electrical Configuration (voltage/phase/hz/amps)	120v /1 / 60hz (3 prong plug)
Suggested Amp Breaker	15
Venting Requirements	Optional. If used 10-14"
Dimensions (wxdxh in inches)	33x37x84
Standard Programmed Cycles	Hose 10 hour / Gear 3 hour
Airflow/Watts of Heating	600 CFM / 1500 watts

With an industry-leading 10-year warranty, we are not only confident that the durability of our Circul-Air cabinet gear dryers will exceed expectations, we stand by it. The Express 2-Gear is a smaller cabinet that is perfect for stations that have limited space and a strict budget. With the smaller footprint, the capacity of the 2-gear is 4 pieces. Including both ambient and heat functions, our 2-gear is the ideal entry level cabinet that is compliant with NFPA 1851:2020.

- Commercial grade, powder coated and galvanized construction for long-lasting durability to dry gear for years to come
- Capacity up to 4 pieces of gear
- Includes: 4 gear hangers, 4 glove hangers, 3 wire racks, 1 boot rack to dry up to 6 pieces of gear at a time
- Compact design optimal for limited space and gear needs
- Proudly made in North America
- 10-year warranty



call: 800-795-1150 option 2
email: sales@circul-air-corp.com
or visit: Circul-Air-Corp.com



PPE EXPRESS 4 GEAR DRYING CABINET

	Part # E412= 240/1/60/30.1
Electrical Configuration (voltage/phase/hz/amps)	Part # E413= 208/1/60/27.5
with Associated Part Number	Part # E433= 240/3/60/19.6
	Part # E434= 208/3/60/17.7
Suggested Amp Breaker	35 (30 for E434)
Venting Requirements	10-14"
Dimensions (wxdxh in inches)	47x34x81.5
Standard Programmed Cycles	Hose 10 hour / Gear 3 hour Hose
Airflow/Watts of Heating	600 CFM / 6000 watts



With an industry-leading 10-year warranty, we are not only confident that the durability of our Circul-Air cabinet gear dryers will exceed expectations, we stand by it. The Express 4-Gear is the smallest of the double-door units and is perfect for stations that have limited space and budget. The Express 4-Gear packs a punch, offering a small footprint while also drying up to 6 pieces of gear. Including both ambient and heat functions, our 4-gear is the ideal standard level cabinet that is compliant with NFPA 1851:2020.

- Commercial grade, powder coated and galvanized construction for long-lasting durability to dry gear for years to come
- Capacity up to 6 pieces of gear
- Includes: 6 gear hangers, 6 glove hangers, 2 wire racks, 1 boot rack to dry up to 6 pieces of gear at a time
- Smallest of the double-door units optimal for limited space and standard gear needs
- Proudly made in North America
- 10-year warranty



call: 800-795-1150 option 2
email: sales@circul-air-corp.com
or visit: Circul-Air-Corp.com



PPE EXPRESS 6 GEAR DRYER



	Part # E612= 240/1/60/30.1
Electrical Configuration (voltage/phase/hz/amps) with Associated Part Number	Part # E613= 208/1/60/27.5 Part # E633= 240/3/60/19.6 Part # E634= 208/3/60/17.7
Suggested Amp Breaker	35 (30 for E634)
Venting Requirements	10-14"
Dimensions (wxdxh in inches)	55x38x82
Standard Programmed Cycles	Hose 10 hour / Gear 3 hour Hose
Airflow/Watts of Heating	900 CFM / 6000 watts

With an industry-leading 10-year warranty, we are not only confident that the durability of our Circul-Air cabinet gear dryers will exceed expectations, we stand by it. The Express 6-Gear cabinet have a capacity of 6-8 pieces of gear and include 4 racks for drying hose. Our negative-pressure design allows for gear to be dried thoroughly without the need for intense heat. This dryer arrives pre programmed to be NFPA 1851:2020 compliant.

- Commercial grade, powder coated and galvanized construction for long-lasting durability to dry gear for years to come
- Capacity up to 8 pieces of gear
- Includes: 6 gear hangers, 6 glove hangers, 3 wire racks, 1 boot rack to dry up to 8 pieces of gear at a time
- Standard sizing optimal for standard space and increased gear needs
- Proudly made in North America
- 10-year warranty

PPE 6XL DUAL PURPOSE DRYER



	Part # D612= 240/1/60/30.1
Electrical Configuration (voltage/phase/hz/amps) with Associated Part Number	Part # D613= 208/1/60/27.5 Part # D633= 240/3/60/19.6 Part # D634= 208/3/60/17.7
Suggested Amp Breaker	35 (30 for D634)
Venting Requirements	10-14"
Dimensions (wxdxh in inches)	47x55x81
Standard Programmed Cycles	Hose 10 hour / Gear 3 hour Hose
Airflow/Watts of Heating	900 CFM / 6000 watts

With an industry-leading 10-year warranty, we are not only confident that the durability of our Circul-Air cabinet gear dryers will exceed expectations, we stand by it. The Dual Purpose Cabinet is ideal for multi-engine stations that want the ability to dry gear and hose. Having the capacity of 8-10 pieces of gear and 500 ft of 5" hose (seperately), this dryer arrives pre-programmed to be NFPA 1851:2020 compliant.

- Commercial grade, powder coated and galvanized construction for long-lasting durability to dry gear for years to come
- Capacity up to 10 pieces of gear
- Includes: 6 gear hangers, 6 glove hangers, 10 wire racks to dry up to 10 pieces of gear at a time
- Largest of the double-door units optimal for larger spaces, increased gear and hose needs
- Proudly made in North America
- 10-year warranty



PORTABLE TURNOUT GEAR DRYER – 2 POSITION



Capacity	2 position
Dimensions (wxdxh in inches)	32x41.75x77
Weight (lbs)	215
Electrical Configuration	120v/60 hz
Recommended Breaker	15 amp
Air Flow Total (cfm)	525
Heat (w)	1500

For stations or applications with limited volume or space constraints, the portable dryer by Circul-Air allows for quick and efficient deployment in the station or on-scene, bringing drying capabilities to where they are needed. With higher ground clearance than the competition, these units can be moved while loaded. The Port-2 is the smallest of the fully mobile dryer options that has a capacity of 2 sets of thermal/moisture barrier liners or 2 sets of outer shells (4-pieces). With an industry-leading low-decibal reading, we provide dry gear while eliminating the exposure noise in the station. Including ambient and heat settings with every dryer ensures your gear is being dried appropriately.

- Commercial grade construction and powder coated for long-lasting durability to dry gear for years to come
- 4 heavy-duty 5" castor wheels (2 fixed, 2 swivel locking)
- Best in class 65 dBA operation at 6', 55 dBA at 10' allowing for use in close proximity to personnel
- Dries 4 pieces of disassembled clothing and an additional 8 pieces of accessory
- Optimal for small or on-scene spaces
- Proudly made in North America
- 3-year warranty

PORTABLE TURNOUT GEAR DRYER – 4 & 6 POSITION



Capacity	4 position 6 position
Dimensions (wxdxh in inches)	4: 32x57x80 6: 32x82x80
Weight (lbs)	4: 260 6: 290
Electrical Configuration	120v/60 hz
Recommended Breaker	15 amp
Air Flow Total (cfm)	525
Heat (w)	1500

For stations with limited volume or space constraints, the portable dryer allows for quick and efficient deployment in the station or on-scene, bringing drying capabilities to where they are needed. With higher ground clearance than the competition, these units can be moved while loaded. The Port-4 is a mid-size portable dryer that has a capacity of up to 8 pieces of gear and the Port-6 is the largest of the mobile dryer options, offering drying capacity for 12 pieces of gear. With an industry-leading low-decibal reading, we provide dry gear while eliminating the exposure noise in the station. Including ambient and heat settings with every dryer ensures your gear is being dried appropriately.

- Commercial grade construction and powder coated for long-lasting durability to dry gear for years to come
- 4 heavy-duty 5" castor wheels (2 fixed, 2 swivel locking)
- Best in class 65 dBA operation at 6', 55 dBA at 10' allowing for use in close proximity to personnel
- Dries 8 (port-4) - 12 (port-6) pieces of disassembled clothing and an additional 16 (port-4) - 24 (port-6) pieces of accessory
- Optimal for small or on-scene spaces
- Proudly made in North America
- 3-year warranty



TURNOUT GEAR TUMBLE DRYER – 23 LBS / 6 PIECES



Capacity (lbs/pieces)	23/6
Door Diameter (in)	22.6
Door to Floor (in)	27
Drum Depth (in)	18.7
Drum Volume (ft ³)	7.42
Electrical Configuration	120v / 1Phase / N 20amp
Gas Inlet (bsp)	1/2
Exhaust	8
Max Airflow (cfm)	500
Dimensions (wxdxh in inches)	31x34x67
Weight (lbs)	379

This 23-lb Tumble Dryer is ideal for centralized drying of multiple stations at one location. This machine operates with the use of both electric and gas, drying more gear in a small footprint. Arriving pre-programmed to provide ISP-capacity drying, its pre-programmed cycles within the dryer ensures that your gear is thoroughly dried, reducing the risk of mold, mildew and bacterial growth. Loading and unloading your gear has never been easier. The tumble dryer's door features a wide 180-degree opening, ensuring convenient access and maneuverability with minimal effort. Circul-Air tumble dryers are full NFPA-1851 2020 edition compliant, which ensures your gear will be dried safely and in a timely fashion.

- Commercial grade construction for long-lasting durability to dry gear for years to come
- Three Pre-Programmed Cycles:
 1. No Heat: Ideal for situations where gentle drying is preferred.
 2. Low Heat: A moderate heat setting for a balanced drying process.
 3. Max Compliant Heat: This setting adheres to the highest of compliant standards.
- Dries up to 6 pieces of gear
- Optimal for ISPs or stations in dryer climates with high gear needs
- 1-year warranty

TURNOUT GEAR TUMBLE DRYER – 30 LBS / 8 PIECES



Capacity (lbs/pieces)	30/8
Door Diameter (in)	22.6
Door to Floor (in)	27
Drum Depth (in)	24
Drum Volume (ft ³)	9.53
Electrical Configuration	120v / 1Phase / N 20amp
Gas Inlet (bsp)	1/2
Exhaust	8
Max Airflow (cfm)	500
Dimensions (wxdxh in inches)	31x39x67
Weight (lbs)	379

This 30-lb Tumble Dryer is ideal for centralized drying of multiple stations at one location. This machine operates with the use of both electric and gas, drying more gear in a small footprint. Arriving pre-programmed to provide ISP-capacity drying, its pre-programmed cycles within the dryer ensures that your gear is thoroughly dried, reducing the risk of mold, mildew and bacterial growth. Loading and unloading your gear has never been easier. The tumble dryer's door features a wide 180-degree opening, ensuring convenient access and maneuverability with minimal effort. Circul-Air tumble dryers are full NFPA-1851 2020 edition compliant, which ensures your gear will be dried safely and in a timely fashion.

- Commercial grade construction for long-lasting durability to dry gear for years to come
- Three Pre-Programmed Cycles:
 1. No Heat: Ideal for situations where gentle drying is preferred.
 2. Low Heat: A moderate heat setting for a balanced drying process.
 3. Max Compliant Heat: This setting adheres to the highest of compliant standards.
- Dries up to 8 pieces of gear
- Optimal for ISPs or stations in dryer climates with high gear needs
- 1-year warranty



TURNOUT GEAR TUMBLE DRYER – 36 LBS / 9 PIECES



Capacity (lbs/pieces)	36/9
Door Diameter (in)	22.6
Door to Floor (in)	27
Drum Depth (in)	29.4
Drum Volume (ft ³)	11.65
Electrical Configuration	120v / 1Phase / N 20amp
Gas Inlet (bsp)	1/2
Exhaust	8
Max Airflow (cfm)	500
Dimensions (wxdxh in inches)	31x44x67
Weight (lbs)	412

This 36-lb Tumble Dryer is ideal for centralized drying of multiple stations at one location. This machine operates with the use of both electric and gas, drying more gear in a small footprint. Arriving pre-programmed to provide ISP-capacity drying, its pre-programmed cycles within the dryer ensures that your gear is thoroughly dried, reducing the risk of mold, mildew and bacterial growth. Loading and unloading your gear has never been easier. The tumble dryer's door features a wide 180-degree opening, ensuring convenient access and maneuverability with minimal effort. Circul-Air tumble dryers are full NFPA-1851 2020 edition compliant, which ensures your gear will be dried safely and in a timely fashion.

- Commercial grade construction for long-lasting durability to dry gear for years to come
- Three Pre-Programmed Cycles:
 1. No Heat: Ideal for situations where gentle drying is preferred.
 2. Low Heat: A moderate heat setting for a balanced drying process.
 3. Max Compliant Heat: This setting adheres to the highest of compliant standards.
- Dries up to 9 pieces of gear
- Optimal for ISPs or stations in dryer climates with high gear needs
- 1-year warranty

TURNOUT GEAR TUMBLE DRYER – 51 LBS / 12 PIECES



Capacity (lbs/pieces)	51/12
Door Diameter (in)	22.6
Door to Floor (in)	29
Drum Depth (in)	31.4
Drum Volume (ft ³)	16.2
Electrical Configuration	120v / 1Phase / N 20amp
Gas Inlet (bsp)	1/2
Exhaust	8
Max Airflow (cfm)	706
Dimensions (wxdxh in inches)	35x49x67
Weight (lbs)	462

This 51-lb Tumble Dryer is ideal for centralized drying of multiple stations at one location. This machine operates with the use of both electric and gas, drying more gear in a small footprint. Arriving pre-programmed to provide ISP-capacity drying, its pre-programmed cycles within the dryer ensures that your gear is thoroughly dried, reducing the risk of mold, mildew and bacterial growth. Loading and unloading your gear has never been easier. The tumble dryer's door features a wide 180-degree opening, ensuring convenient access and maneuverability with minimal effort. Circul-Air tumble dryers are full NFPA-1851 2020 edition compliant, which ensures your gear will be dried safely and in a timely fashion.

- Commercial grade construction for long-lasting durability to dry gear for years to come
- Three Pre-Programmed Cycles:
 1. No Heat: Ideal for situations where gentle drying is preferred.
 2. Low Heat: A moderate heat setting for a balanced drying process.
 3. Max Compliant Heat: This setting adheres to the highest of compliant standards.
- Dries up to 12 pieces of gear
- Optimal for ISPs or stations in dryer climates with high gear needs
- 1-year warranty



TURNOUT GEAR TUMBLE DRYER – 60 LBS / 15 PIECES



Capacity (lbs/pieces)	60/15
Door Diameter (in)	31.6
Door to Floor (in)	25.2
Drum Depth (in)	30.7
Drum Vol ft3	19.4
Electrical Configuration	120v / 1Phase / N 20amp
Gas Inlet (bsp)	1/2
Exhaust	8
Max Airflow (cfm)	706
Dimensions (wxdxh in inches)	38.8x41.5x78
Weight (lbs)	507

This 60-lb Tumble Dryer is ideal for centralized drying of multiple stations at one location. This machine operates with the use of both electric and gas, drying more gear in a small footprint. Arriving pre-programmed to provide ISP-capacity drying, its pre-programmed cycles within the dryer ensures that your gear is thoroughly dried, reducing the risk of mold, mildew and bacterial growth. Loading and unloading your gear has never been easier. The tumble dryer's door features a wide 180-degree opening, ensuring convenient access and maneuverability with minimal effort. Circul-Air tumble dryers are full NFPA-1851 2020 edition compliant, which ensures your gear will be dried safely and in a timely fashion.

- Commercial grade construction for long-lasting durability to dry gear for years to come
- Three Pre-Programmed Cycles:
 1. No Heat: Ideal for situations where gentle drying is preferred.
 2. Low Heat: A moderate heat setting for a balanced drying process.
 3. Max Compliant Heat: This setting adheres to the highest of compliant standards.
- Dries up to 15 pieces of gear
- Optimal for ISPs or stations in dryer climates with high gear needs
- 1-year warranty

TURNOUT GEAR TUMBLE DRYER – 75 LBS / 18 PIECES

Capacity (lbs/pieces)	75/18
Door Diameter (in)	31.6
Door to Floor (in)	25.2
Drum Depth (in)	36.9
Drum Vol ft3	23.3
Electrical Configuration	120v / 1Phase / N 20amp
Gas Inlet (bsp)	1/2
Exhaust	8
Max Airflow (cfm)	706
Dimensions (wxdxh in inches)	38.8x41.5x78
Weight (lbs)	573



This 75-lb Tumble Dryer is ideal for centralized drying of multiple stations at one location. This machine operates with the use of both electric and gas, drying more gear in a small footprint. Arriving pre-programmed to provide ISP-capacity drying, its pre-programmed cycles within the dryer ensures that your gear is thoroughly dried, reducing the risk of mold, mildew and bacterial growth. Loading and unloading your gear has never been easier. The tumble dryer's door features a wide 180-degree opening, ensuring convenient access and maneuverability with minimal effort. Circul-Air tumble dryers are full NFPA-1851 2020 edition compliant, which ensures your gear will be dried safely and in a timely fashion.

- Commercial grade construction for long-lasting durability to dry gear for years to come
- Three Pre-Programmed Cycles:
 1. No Heat: Ideal for situations where gentle drying is preferred.
 2. Low Heat: A moderate heat setting for a balanced drying process.
 3. Max Compliant Heat: This setting adheres to the highest of compliant standards.
- Dries up to 18 pieces of gear
- Optimal for ISPs or stations in dryer climates with high gear needs
- 1-year warranty



Store It.



Built to Last

Ventilation Prevents Odor, Mold & Bacteria

**Extendable or Mobile Design to Suit your Unique
Station Layout**

Customizable Accessories to Suit your Needs

Proudly Made in North America

WALL MOUNT GEAR STORAGE LOCKER



The wall-mounted gear lockers provide a space-saving storage option. The North American, 4-point construction provides structural stability within wall-mounted lockers. Offering endless locker combinations provides the station with the ability to fulfill their unique storage needs.

- Heavy-duty steel 4-point construction
- 1.25" 16GA square and round tube; ¼" wire
- Adjustable helmet/boot shelves
- Fixed hanger bar and nameplate
- Rugged powder coat finish
- Colors: red, gray, blue (custom colors available)
- Security option is available to secure

gear and personal items

- Locker runs unlimited based on modular design
- Fixed solid-aluminum hanger bar
- Each assembly kit includes all hardware needed to complete assembly of storage system. Exception: wall hardware to attach wall mount bracket to wall is not included.
- See accessory section for add-on hangers for gear, gloves and boots
- Skid and freight extra and calculated on best way methods
- Proudly made in North America

18" Wide Openings Wall Mount Gear Storage	Dimensions (wxdxh in inches)	Part Number w/o security	Part Number w/optional security
18" Wide Lockers 2 position	39x21x78*	CAC-WMGL-18/02	CAC-WMGL-18/02+sec
18" Wide Lockers 3 position	58x21x78*	CAC-WMGL-18/03	CAC-WMGL-18/03+sec
18" Wide Lockers 4 position	77x21x78*	CAC-WMGL-18/04	CAC-WMGL-18/04+sec
18" Wide Lockers 5 position	96x21x78*	CAC-WMGL-18/05	CAC-WMGL-18/05+sec
18" Wide Lockers 6 position	115x21x78*	CAC-WMGL-18/06	CAC-WMGL-18/06+sec
18" Wide Lockers 7 position	134x21x78*	CAC-WMGL-18/07	CAC-WMGL-18/07+sec
18" Wide Lockers 8 position	153x21x78*	CAC-WMGL-18/08	CAC-WMGL-18/08+sec
18" Wide Lockers 9 position	172x21x78*	CAC-WMGL-18/09	CAC-WMGL-18/09+sec
18" Wide Lockers 10 position	191x21x78*	CAC-WMGL-18/10	CAC-WMGL-18/10+sec

20" Wide Openings Wall Mount Gear Storage	Dimensions (wxdxh in inches)	Part Number w/o security	Part Number w/optional security
20" Wide Lockers 2 position	43x21x78*	CAC-WMGL-20/02	CAC-WMGL-20/02+sec
20" Wide Lockers 3 position	64x21x78*	CAC-WMGL-20/03	CAC-WMGL-20/03+sec
20" Wide Lockers 4 position	85x21x78*	CAC-WMGL-20/04	CAC-WMGL-20/04+sec
20" Wide Lockers 5 position	106x21x78*	CAC-WMGL-20/05	CAC-WMGL-20/05+sec
20" Wide Lockers 6 position	127x21x78*	CAC-WMGL-20/06	CAC-WMGL-20/06+sec
20" Wide Lockers 7 position	148x21x78*	CAC-WMGL-20/07	CAC-WMGL-20/07+sec
20" Wide Lockers 8 position	169x21x78*	CAC-WMGL-20/08	CAC-WMGL-20/08+sec
20" Wide Lockers 9 position	190x21x78*	CAC-WMGL-20/09	CAC-WMGL-20/09+sec
20" Wide Lockers 10 position	211x21x78*	CAC-WMGL-20/10	CAC-WMGL-20/10+sec

24" Wide Openings Wall Mount Gear Storage	Dimensions (wxdxh in inches)	Part Number w/o security	Part Number w/optional security
24" Wide Lockers 2 position	51x21x78*	CAC-WMGL-24/02	CAC-WMGL-24/02+sec
24" Wide Lockers 3 position	76x21x78*	CAC-WMGL-24/03	CAC-WMGL-24/03+sec
24" Wide Lockers 4 position	101x21x78*	CAC-WMGL-24/04	CAC-WMGL-24/04+sec
24" Wide Lockers 5 position	126x21x78*	CAC-WMGL-24/05	CAC-WMGL-24/05+sec
24" Wide Lockers 6 position	151x21x78*	CAC-WMGL-24/06	CAC-WMGL-24/06+sec
24" Wide Lockers 7 position	176x21x78*	CAC-WMGL-24/07	CAC-WMGL-24/07+sec
24" Wide Lockers 8 position	201x21x78*	CAC-WMGL-24/08	CAC-WMGL-24/08+sec
24" Wide Lockers 9 position	226x21x78*	CAC-WMGL-24/09	CAC-WMGL-24/09+sec
24" Wide Lockers 10 position	251x21x78*	CAC-WMGL-24/10	CAC-WMGL-24/10+sec

* Height dimension based on standard 6" clearance. Floor clearance subject to client modification.



FREE STANDING (SINGLE AND DUAL SIDED) GEAR STORAGE LOCKER

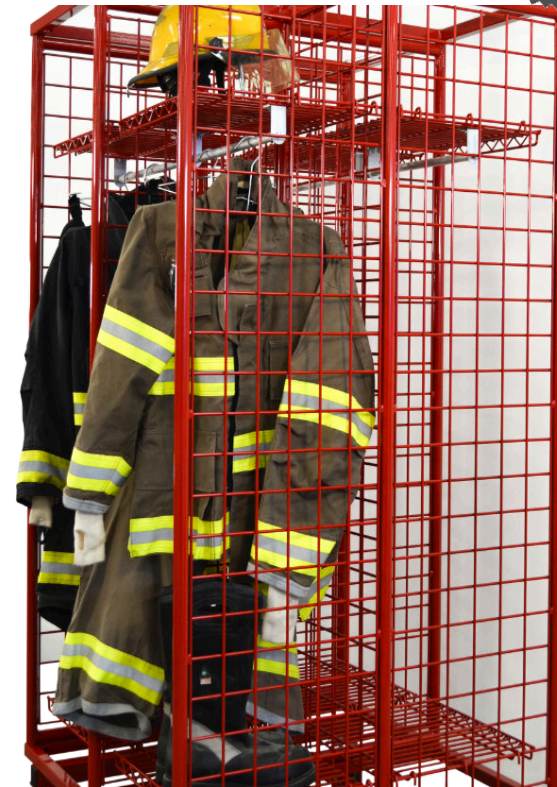

The free-standing locker is similar to the build of the mobile lockers except the leveling feet temporarily fix them to a location. With the ease of installation, the free-standing option provides the flexibility of the mobile with the simplified installation of the wall-mounted. The robust design offers stability without being fixed to the wall. The variety of sizes and color options provides the opportunity to customize your storage needs.

- Heavy-duty steel 4-point construction
- 1.25" 16GA square and round tube; ¼" wire
- Adjustable helmet/boot shelves
- Adjustable free-standing feet
- Fixed hanger bar and nameplate

- Rugged powder coat finish
- Colors: red, gray, blue (custom colors available)
- Security option is available to secure gear and personal items
- Locker runs unlimited based on modular design
- Fixed solid-aluminum hanger bar
- Each assembly kit includes all hardware needed to complete assembly of storage system
- See accessory section for add-on hangers for gear, gloves and boots
- Skid and freight extra and calculated on best way methods
- Proudly made in North America

18" Wide Openings Free Standing Gear Storage	Dimensions (wxdxh in inches)	Part Number w/o security	Part Number w/optional security
18" Wide Lockers 2 position	39x21x81	CAC-FSGL-18/02	CAC-FSGL-18/02+sec
18" Wide Lockers 3 position	58x21x81	CAC-FSGL-18/03	CAC-FSGL-18/03+sec
18" Wide Lockers 4 position	77x21x81	CAC-FSGL-18/04	CAC-FSGL-18/04+sec
18" Wide Lockers 5 position	96x21x81	CAC-FSGL-18/05	CAC-FSGL-18/05+sec
18" Wide Lockers 6 position	115x21x81	CAC-FSGL-18/06	CAC-FSGL-18/06+sec
18" Wide Lockers 7 position	134x21x81	CAC-FSGL-18/07	CAC-FSGL-18/07+sec
18" Wide Lockers 8 position	153x21x81	CAC-FSGL-18/08	CAC-FSGL-18/08+sec
18" Wide Lockers 9 position	172x21x81	CAC-FSGL-18/09	CAC-FSGL-18/09+sec
18" Wide Lockers 10 position	191x21x81	CAC-FSGL-18/10	CAC-FSGL-18/10+sec
20" Wide Openings Free Standing Gear Storage	Dimensions (wxdxh in inches)	Part Number w/o security	Part Number w/optional security
20" Wide Lockers 2 position	43x21x81	CAC-FSGL-20/02	CAC-FSGL-20/02+sec
20" Wide Lockers 3 position	64x21x81	CAC-FSGL-20/03	CAC-FSGL-20/03+sec
20" Wide Lockers 4 position	85x21x81	CAC-FSGL-20/04	CAC-FSGL-20/04+sec
20" Wide Lockers 5 position	106x21x81	CAC-FSGL-20/05	CAC-FSGL-20/05+sec
20" Wide Lockers 6 position	127x21x81	CAC-FSGL-20/06	CAC-FSGL-20/06+sec
20" Wide Lockers 7 position	148x21x81	CAC-FSGL-20/07	CAC-FSGL-20/07+sec
20" Wide Lockers 8 position	169x21x81	CAC-FSGL-20/08	CAC-FSGL-20/08+sec
20" Wide Lockers 9 position	190x21x81	CAC-FSGL-20/09	CAC-FSGL-20/09+sec
20" Wide Lockers 10 position	211x21x81	CAC-FSGL-20/10	CAC-FSGL-20/10+sec
24" Wide Openings Free Standing Gear Storage	Dimensions (wxdxh in inches)	Part Number w/o security	Part Number w/optional security
24" Wide Lockers 2 position	51x21x81	CAC-FSGL-24/02	CAC-FSGL-24/02+sec
24" Wide Lockers 3 position	76x21x81	CAC-FSGL-24/03	CAC-FSGL-24/03+sec
24" Wide Lockers 4 position	101x21x81	CAC-FSGL-24/04	CAC-FSGL-24/04+sec
24" Wide Lockers 5 position	126x21x81	CAC-FSGL-24/05	CAC-FSGL-24/05+sec
24" Wide Lockers 6 position	151x21x81	CAC-FSGL-24/06	CAC-FSGL-24/06+sec
24" Wide Lockers 7 position	176x21x81	CAC-FSGL-24/07	CAC-FSGL-24/07+sec
24" Wide Lockers 8 position	201x21x81	CAC-FSGL-24/08	CAC-FSGL-24/08+sec
24" Wide Lockers 9 position	226x21x81	CAC-FSGL-24/09	CAC-FSGL-24/09+sec
24" Wide Lockers 10 position	251x21x81	CAC-FSGL-24/10	CAC-FSGL-24/10+sec
18" Free Standing Dual Side Locker	Dimensions (wxdxh in ")	Part Number w/o security	Part Number w/optional security
18" 2 Each Side - total 4 position	39 x 41x 81	CAC-FSDGL-18/D4	CAC-FSDGL-18/D4+sec
18" 3 Each Side - total 6 position	58x 41x 81	CAC-FSDGL-18/D6	CAC-FSDGL-18/D6+sec
18" 4 Each Side - total 8 position	77x 41x 81	CAC-FSDGL-18/D8	CAC-FSDGL-18/D8+sec
20" Free Standing Dual Side Locker			
20" 2 Each Side - total 4 position	43x41x81	CAC-FSDGL-20/D4	CAC-FSDGL-20/D4+sec
20" 3 Each Side - total 6 position	64x41x81	CAC-FSDGL-20/D6	CAC-FSDGL-20/D6+sec
24" Free Standing Dual Side Locker			
24" 2 Each Side - total 4 position	51x41x81	CAC-FSDGL-24/D4	CAC-FSDGL-24/D4+sec
24" 3 Each Side - total 6 position	76x41x81	CAC-FSDGL-24/D6	CAC-FSDGL-24/D6+sec

call: 800-795-1150 option 2
 email: sales@circul-air-corp.com
 or visit: Circul-Air-Corp.com



MOBILE (SINGLE AND DUAL SIDED) GEAR STORAGE LOCKER



The mobile lockers offer the ability to maximize storage anywhere in the station. These fully-mobile storage racks are built to last with our 4-point construction design that is North American made. Offered in 18, 20 and 24 inches with the option of custom colors, we provide options that fit your station's needs.

- Heavy-duty steel 4-point construction
- 1.25" 16GA square and round tube; ¼" wire
- Adjustable helmet/boot shelves
- 4 rugged 5" castor wheels (2 fixed, 2 swivel locking)
- Fixed hanger bar and nameplate
- Rugged powder coat finish

- Colors: red, gray, blue (custom colors available)
- Security option is available to secure gear and personal items
- Locker runs unlimited based on modular design. Wheels make movement easy
- Fixed solid-aluminum hanger bar
- Each assembly kit includes all hardware needed to complete assembly of storage system
- See accessory section for add-on hangers for gear, gloves and boots
- Skid and freight extra and calculated on best way methods
- Proudly made in North America

18" Mobile Gear Storage Lockers	Dimensions (wxdxh in inches)	Part Number w/o security	Part Number w/optional security
18" Lockers Single Sided - 2 position	39x21x81	CAC-MBGL-18/2	CAC-MBGL-18/2+sec
18" Lockers Single Sided - 3 position	58x21x81	CAC-MBGL-18/3	CAC-MBGL-18/3+sec
18" Lockers Single Sided - 4 position	77x21x81	CAC-MBGL-18/4	CAC-MBGL-18/4+sec
20" Mobile Gear Storage Lockers			
20" Lockers Single Sided - 2 position	43x21x81	CAC-MBGL-20/2	CAC-MBGL-20/2+sec
20" Lockers Single Sided - 3 position	64x21x81	CAC-MBGL-20/3	CAC-MBGL-20/3+sec
24" Free Standing Lockers			
24" Lockers Single Sided - 2 position	51x21x81	CAC-MBGL-24/2	CAC-MBGL-24/2+sec
24" Lockers Single Sided - 3 position	76x21x81	CAC-MBGL-24/3	CAC-MBGL-24/3+sec

18" Mobile Dual Sided Lockers	Dimensions (wxdxh in inches)	Part Number w/o security	Part Number w/optional security
18" 2 Lockers Each Side - total 4 position	39x41x81	CAC-MBDGL-18/D4	CAC-MBDGL-18/D4+sec
18" 3 Lockers Each Side - total 6 position	58x41x81	CAC-MBDGL-18/D6	CAC-MBDGL-18/D6+sec
18" 4 Lockers Each Side - total 8 position	77x41x81	CAC-MBDGL-18/D8	CAC-MBDGL-18/D8+sec
20" Mobile Dual Sided Lockers			
20" 2 Lockers Each Side - total 4 position	43x41x81	CAC-MBDGL-20/D4	CAC-MBDGL-20/D4+sec
20" 3 Lockers Each Side - total 6 position	64x41x81	CAC-MBDGL-20/D6	CAC-MBDGL-20/D6+sec
24" Mobile Dual Sided Lockers			
24" 2 Lockers Each Side - total 4 position	51x41x81	CAC-MBDGL-24/D4	CAC-MBDGL-24/D4+sec
24" 3 Lockers Each Side - total 6 position	76x41x81	CAC-MBDGL-24/D6	CAC-MBDGL-24/D6+sec



DUAL PURPOSE DRYING RACK



Dimensions (wxdxh in inches)	8x33x88
Approximate Capacity	Up to 800' of 2.5" - 3" Hose
Part Number	CAC-HRLG

Keeping your gear organized is made simple with Circul-Air's variety of fire department storage options. Each locker and storage unit is designed to stand up against the test of time, with the accessibility needed to be able to grab PPE at a moment's notice. With the portable option, transporting heavy-duty gear throughout the firehouse has never been easier. Time-tested in active fire stations, the Circul-Air dual purpose drying rack is built to last!

- Rugged steel construction
- Durable powder coat finish
- 4 rugged 5" castor wheels (2 fixed, 2 swivel locking)
- Colors: gray
- Skid and freight extra and calculated on best way methods
- Ships knocked-down for freight savings
- Proudly made in North America

8FT LONG WALL OR FLOOR MOUNT HOSE RACK



2 Tier Height Options	
Dimensions (wxdxh in inches)	WM: 102x48x96 FM: 102x48x120
Approximate Capacity (of 50' sections of 2.5" hose)	60 Sections
Part Number	CAC-2LEV-8FT-WM CAC-2LEV-8FT-FM
3 Tier Height Options	
Dimensions (wxdxh in inches)	WM: 102x48x96 FM: 102x48x120
Approximate Capacity (of 50' sections of 2.5" hose)	90 Sections
Part Number	CAC-3LEV-8FT-WM CAC-3LEV-8FT-FM

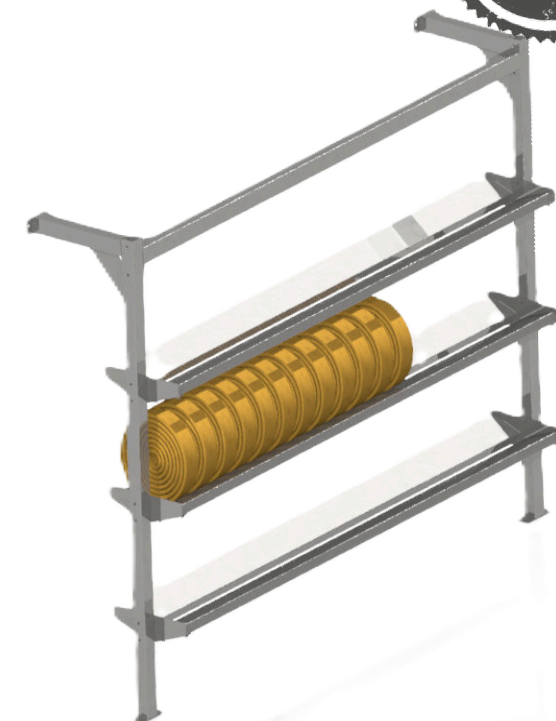

Ensuring your hose is kept clean and stored properly will increase its lifespan and eliminate issues with it in the field. Time-tested in active fire stations, the Circul-Air hose rack is built to last, providing grab-and-go storage for years to come!

- Rugged steel construction
- Durable powder coat finish
- 3000 lb capacity
- Colors: red or gray
- Each assembly kit includes all hardware needed to complete assembly of storage system. Exception: wall hardware to attach wall mount bracket to wall is not included
- Skid and freight extra and calculated on best way methods
- Proudly made in North America



PORTABLE HOSE RACK



2 Tier Height Options-5ft Long	
Dimensions (wxdxh in inches)	72x34x80
Approximate Capacity (of 50' sections of 2.5" hose)	40 Sections
Part Number	CAC-2LEV-5FT-MB
2 Tier Height Options-8ft Long	
Dimensions (wxdxh in inches)	104x34x80
Approximate Capacity (of 50' sections of 2.5" hose)	60 Sections
Part Number	CAC-2LEV-8FT-MB
3 Tier Height Options-5ft Long	
Dimensions (wxdxh in inches)	72x34x88
Approximate Capacity (of 50' sections of 2.5" hose)	60 Sections
Part Number	CAC-3LEV-5FT-MB
3 Tier Height Options-8ft Long	
Dimensions (wxdxh in inches)	104x34x88
Approximate Capacity (of 50' sections of 2.5" hose)	90 Sections
Part Number	CAC-3LEV-8FT-MB

Keeping your gear organized is made simple with Circul-Air's variety of fire department storage options. Each locker and storage unit is designed to stand up against the test of time, with the accessibility needed to be able to grab PPE at a moment's notice. With the portable option, transporting heavy-duty hose throughout the firehouse has never been easier. Additionally, ensuring your hose is kept clean and stored properly will increase its lifespan and eliminate issues with it in the field. Time-tested in active fire stations, the Circul-Air portable hose rack is built to last!

- Rugged steel construction
- Durable powder coat finish
- 4 rugged 5" castor wheels (2 fixed, 2 swivel locking)
- 3000 lb capacity
- Colors: red or gray
- Each assembly kit includes all hardware needed to complete assembly of storage system
- Skid and freight extra and calculated on best way methods
- Proudly made in North America

MOBILE WORK OR STORAGE CABINETS



Dimensions (wxdxh in inches)	Part Number
43-1/4 X 21 X 35-3/8	CAC-MBTB36-20-2
64-1/4 X 21 X 35-3/8	CAC-MBTB36-20-3
51-1/4 X 21 X 35-3/8	CAC-MBTB36-24-2
76-1/4 X 21 X 35-3/8	CAC-MBTB36-24-3
43-1/4 X 21 X 47-3/8	CAC-MBTB48-20-2
64-1/4 X 21 X 47-3/8	CAC-MBTB48-20-3
51-1/4 X 21 X 47-3/8	CAC-MBTB48-24-2
76-1/4 X 21 X 47-3/8	CAC-MBTB48-24-3
43-1/4 X 21 X 59-7/8	CAC-MBTB60-20-2
64-1/4 X 21 X 59-7/8	CAC-MBTB60-20-3
51-1/4 X 21 X 59-7/8	CAC-MBTB60-24-2
76-1/4 X 21 X 59-7/8	CAC-MBTB60-24-3

Contact sales for: stainless, mild or alternative tabletop materials; SCBA shelf options; custom cabinet construction for shows or service vehicles



Circul-Air mobile work or storage cabinets provide flexible options for the management of equipment at the station or for field operations. Available in the same standard widths as our proven lockers, these are available in 20" or 24" openings, with 36", 48" or 60" heights. Each unit comes with an aluminum checker-plate top, wire shelf (2 for 36" and 48", 3 for 60") and rugged casters. At time of order, diamond plate can be substituted for stainless or mild powder coated top, a standard gear hanging shelf or 21" deep SCBA bottle shelf.

- Heavy-duty steel 4-point construction
- 1.25" 16GA square and round tube; 1/4" wire
- 4 rugged 5" castor wheels (2 fixed, 2 swivel locking)
- Customizable features to suit your station's needs
- Colors: red, gray, blue (custom colors available)
- Proudly made in North America



Accessories Warranty & Support



Dryer and Storage Accessories to Suit your Station

Dedicated North American Wide Team to Support

Expert Design and Installation Advice

In-House Engineers



	Dimensions	Part Number
Dryer Express 2 Gear Shelves		
Single Hose Shelf for 2 Gear Cabinet	24.25"w x 27x.25"d	PPE-2-HS
Single Hose Shelf Kit with Runners and hose shelf	24.25"w x 27x.25"d	PPE-2-HSK
Single Boot Shelf for 2 Gear Cabinet	24.25"w x 27x.25"d	PPE-2-BS
Single Boot Shelf Kit with Runners and hose shelf	24.25"w x 27x.25"d	PPE-2-BSK
Shelf Install Kit for 2 Gear Cabinet		PPE-2-INS
Dryer Express 6 Gear Shelves		
Single Hose Shelf for 6 Gear Cabinet	49.5"w x 28.25"d	PPE-6-HS
Single Hose Shelf Kit with Runners and hose shelf	49.5"w x 28.25"d	PPE-6-HSK
Single Boot Shelf for 6 Gear Cabinet	49.5"w x 28.25"d	PPE-6-BS
Single Boot Shelf Kit with Runners and hose shelf	49.5"w x 28.25"d	PPE-6-BSK
Shelf Install Kit for 6 Gear Cabinet		PPE-6-INS
Dryer Dual Cabinet Gear Shelves		
Single Hose Shelf for 6 Gear Dual Cabinet	48.25"w x 48.25"d	PPE-6X-HS
Dryer Gear Hangers / Holders		
Single Boot / Glove Hanger	7" w x 17" h	CAC-BGH
Single Gear Hanger	18" w x 7" h	CAC-GH
Single Pant Hanger	13" w x 5" h	CAC-PH
Helmet Holder		CAC-HH

	Part Number
Locker Security Panels	
Single Sided Rear Security Panel, 18"	CAC-SECRP-18
Single Sided Rear Security Panel, 20"	CAC-SECRP-20
Single Sided Rear Security Panel, 24"	CAC-SECRP-24
Locker Security Doors	
Standard Security Door, 18"	CAC-SECD-18
Standard Security Door, 20"	CAC-SECD-20
Standard Security Door, 24"	CAC-SECD-24
Locker Security Shelf	
Standard Top Security Shelf, 18"	CAC-SECTS-18
Standard Top Security Shelf, 20"	CAC-SECTS-20
Standard Top Security Shelf, 24"	CAC-SECTS-24
Locker Hanging Bar Kit	
Aluminum Hanging Bar, 18"	CAC-BAR-18
Aluminum Hanging Bar, 20"	CAC-BAR-20
Aluminum Hanging Bar, 24"	CAC-BAR-24
Locker Helmet Shelf	
Standard Helmet Shelf, 18"	CAC-SHLFH-18
Standard Helmet Shelf, 20"	CAC-SHLFH-20
Standard Helmet Shelf, 24"	CAC-SHLFH-24
Locker Boot Shelf	
Standard Boot Shelf, 18"	CAC-SHLFB-18
Standard Boot Shelf, 20"	CAC-SHLFB-20
Standard Boot Shelf, 24"	CAC-SHLFB-24
Locker Miscellaneous	
Wall Mount Bracket	CAC-WMBK
Security Door Hinge Kit	CAC-SECDHK
Freestanding Locker Leg	CAC-FSLL
Locker Storage Box	CAC-LKB



SERVICE & WARRANTY COMMITMENT:

24/48 ACKNOWLEDGE AND RESPOND PLAN

The Circul-Air Service Department will acknowledge your inquiry within 24 hrs. Circul-Air communicates an action plan to investigate and resolve issues within 48 hours.

Dedicated North American wide team of technicians & consultants
service@circul-air-corp.com
1-800-795-1150 opt. 3

INSTALLATION SERVICES:

Circul-Air is here to help with start-to-finish solutions for your gear maintenance needs. Our dedicated installation team is able to guide you when preparing to install and installing your Circul-Air application. Pre-installation review may require blueprints or video conferencing.

- Complimentary Pad-Ready Review
 - Site planning and review
 - Install readiness
 - Flooring, electrical, and water supply and drainage confirmation
- Does not include HVAC configuration; refer to local HVAC technician

Dedicated North American wide team of technicians & consultants
service@circul-air-corp.com
1-800-795-1150 opt. 3

DESIGN SERVICES:

Experience the Circul-Air difference with our design support expertise. Our in-house engineers are eager to assist with a variety of design services and support.

- Product Selection and Sizing
- Storage Layout Design and 3D Bid Drawings
- Review of Specifications for Grants, Bid Packages or Architectural Needs
- Custom Machine Design or Unique Process Solutions

Dedicated North American wide team of technicians & consultants
sales@circul-air-corp.com
1-800-795-1150 opt. 2

SUPPORT TEAMS:

PRE-SALE SUPPORT:

Do you need a quote on one or more items? Questions about grants or major project pricing? The Circul-Air sales team is there for you.

POST-SALE SUPPORT:

Do you have a question about incorporating or installing a Circul-Air product into your station? This team is happy to help with your appliance needs.

AFTERMARKET SUPPORT:

Our machines seem to last forever, but occasionally questions come up and parts need replacing. Circul-Air aftermarket is ready to help.

Dedicated North American wide team of technicians & consultants
sales@circul-air-corp.com
1-800-795-1150 opt. 2





**FIGHT FIRES.
NOT CANCER.**

We Make NFPA-1851 Compliance Easy.

Available through your Local Distributor

Or contact the Circul-Air Sales Team @

call: 800-795-1150 option 2

email: sales@circul-air-corp.com

or visit: Circul-Air-Corp.com

